



**2-wire loop powered toxic and  
Oxygen gas detector for use in  
potentially explosive atmospheres  
- explosion proof and intrinsically  
safe versions**

# Series 3000 MkII and MkIII



## Reliable detection

- Proven electrochemical sensing technology
- Uses Surecell™ electrochemical cells, ideal for hot and humid environments
- Long-life sensing elements
- Patented 'Reflex' sensing element verification diagnostics

## Reduced installation costs

- Integral surface mounting lugs
- Optional horizontal or vertical pipe mounting bracket
- Flameproof transmitter allows field wiring to be run along with other non-IS instruments
- Plug-in sensor removes wiring
- Can be retrofitted in place of Series 2000

## Reduced commissioning costs

- Sensor recognition feature auto configures transmitter
- Non-intrusive configuration
- Plug and play factory configured sensors

## Reduced maintenance costs

- IS sensor connection permits hot swap, reducing downtime
- User programmable calibration frequency
- Integral fault diagnostic software
- Menu/icon driven calibration procedure

## Regulatory compliance

- European (ATEX)
- US (UL)
- Canadian (c-UL)
- South America (Inmetro)
- International (IECEX)

## Range of optional accessories

- Remote sensor mounting kit
- Duct mounting kit (for H<sub>2</sub>, CO and H<sub>2</sub>S only)
- Calibration cup to apply test gas
- Collecting cone

## Typical applications

- Exploration and drilling platform
- Production platforms
- Onshore oil and gas terminals
- Refineries and chemical plants
- Power plants
- Waste water facilities
- Utilities

The Series 3000 range of transmitters provide comprehensive monitoring of toxic and Oxygen gas hazards in potentially explosive atmospheres. Suitable for mounting both indoors and out, they are available in two versions and offer excellent versatility. The MkII is contained in a flameproof housing, has an intrinsically safe sensor connection and is for use in predominantly Zone 1 applications. However with the use of the optional remote mounting kit the sensor of the MkII can be mounted in a Zone 0 environment. The MkIII is for use with a separate suitable IS barrier allowing the complete transmitter to be used in Zone 0 applications.

These low powered gas detectors all feature a loop powered 4-20 mA connection, making them ideal for both new and retrofit installations. Users can configure the detector through the use of the easy to read LCD and intuitive interface while fault diagnostic software and a programmable calibration period greatly simplify maintenance procedures.



The intrinsically safe smart sensors are supplied pre-configured and can be 'hot swapped' without having to remove power to the detector, saving time and money during commissioning and routine servicing. A remote sensor mounting kit is available that allows the sensor to be mounted up to 15m (50ft) from the transmitter, making it ideal for operation in areas that are difficult to access.

Series 3000 is supplied with all necessary accessories for easy installation. The detector can be wall mounted using the integral mounting lugs or pipe mounted (horizontal or vertical) using the optional pipe mounting kit. Electrical installation is made using the 2 x M20 cable entries (ATEX/IECEX version) or 2 x 3/4"NPT conduit entries (UL/c-UL versions). A suitable blanking plug is also supplied to seal any unused entries. A weatherproof cap is included for use in the harshest outdoor conditions.

# Installation



## Mechanical Installation Options

Series 3000 MkII and MkIII are designed for use in potentially explosive atmospheres. As such, installation should follow national guidelines using suitable mechanically protected cable and glands (M20 or ¾" NPT) or conduit (¾" NPT). Use 0.5mm<sup>2</sup> (20AWG) to 2.0mm<sup>2</sup> (~14AWG) cross sectional area cable as needed to ensure minimum operating voltage at the detector, depending on installed cable length. Various accessories are available for different applications.

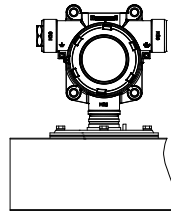

Duct Mount

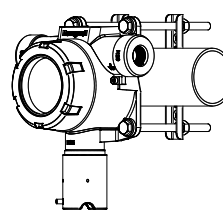

Pipe Mounting

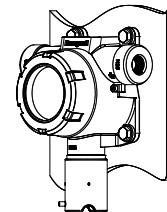

Wall Mount

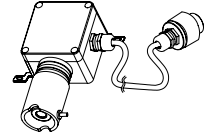

Remote Mounting

## Dimensions

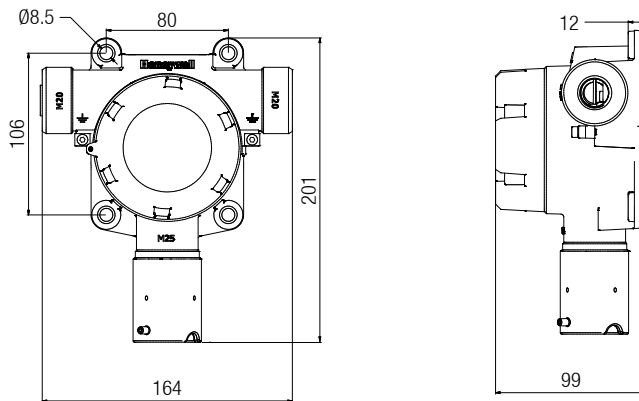

## Remote Mounting Arrangement

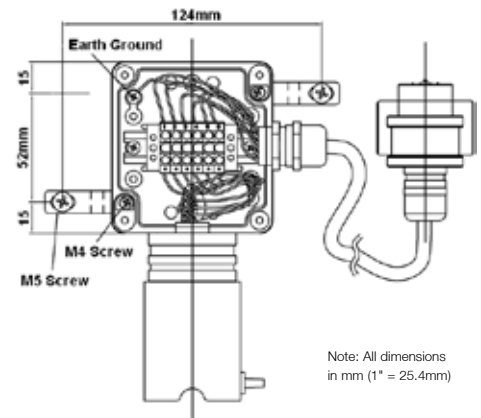

## Wiring Schematics Series 3000 MkII

### Detector supply $V_d$

- 17Vdc (min) to 32Vdc (max)

### Maximum detector signal $I_m$

- 22mA (over range)

### Cable resistance $R_c$

- Subject to cable type

### Load resistor of control panel $R_L$

- Assumed 33Ω (min) or 250Ω (max)
- Subject to controller manufacturer

### Controller supply voltage $V_c$

- Subject to controller manufacturer
- Assumed nominal of 24Vdc

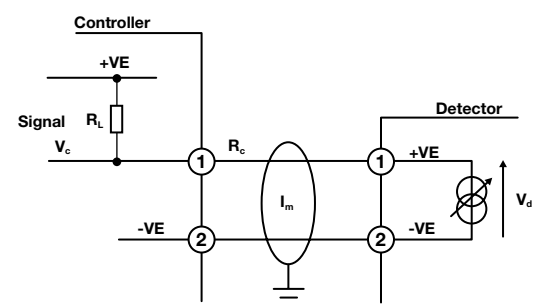
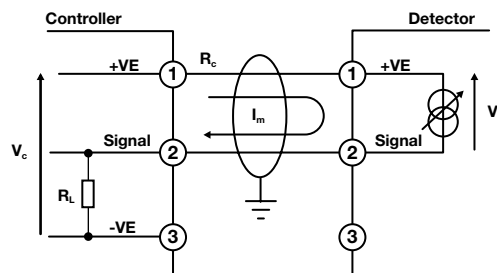

## Typical Maximum Installed Cable Lengths Series 3000 MkII

The maximum cable length between a controller and detector is dependent upon:

- The minimum guaranteed supply voltage to the detector at the controller ( $V_c$ ).
- The minimum operating voltage of the detector ( $V_d$ )
- The maximum current draw of the detector ( $I_m$ )
- The input impedance of the controller ( $R_L$ )
- The resistance of the cable ( $R_c$ )

Using the example values, the table opposite shows typical cable lengths.

For a specific application, the cable manufacturer's resistance data for a specific cable type must be used.

A cable length calculation formula can be found in the product technical manual.

## Series 3000 MkII Maximum Cable Length shown in km (mi)

Cable Size	Cable Resistance $R_c$ Ω/km (Ω/mi)	Cable distance km (mi) where the Input Impedance $R_L = 33Ω$	Cable distance km (mi) where the Input Impedance $R_L = 250Ω$
0.5mm <sup>2</sup> (20AWG*)	36.8 (59.2)	3.9 (2.4)	0.9 (0.6)
1.0mm <sup>2</sup> (17AWG*)	19.5 (31.4)	7.3 (4.5)	1.7 (1.1)
1.5mm <sup>2</sup> (16AWG*)	12.7 (20.4)	11.2 (7.0)	2.7 (1.7)
2.0mm <sup>2</sup> (14AWG*)	10.1 (16.3)	14.1 (8.8)	3.4 (2.1)

\*Nearest equivalent

# Installation



## Wiring Schematics Series 3000 MkIII

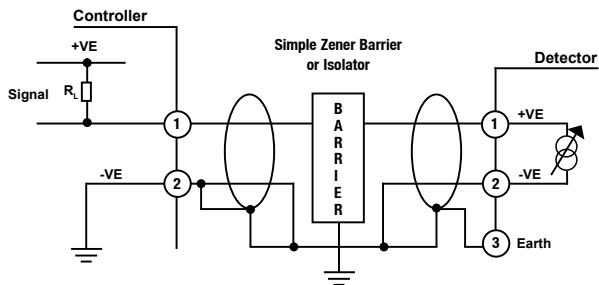

Single Barrier Schematic

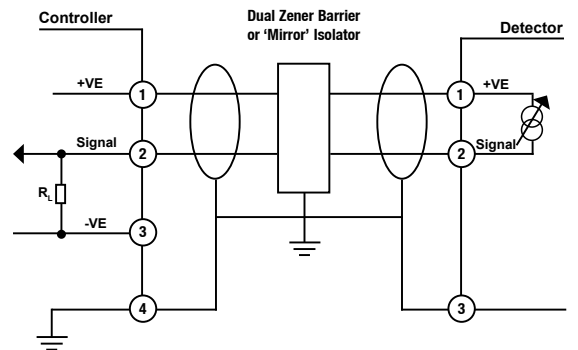

Dual Barrier Schematic

## Series 3000 MkIII Cable Length

The limiting factors in calculating maximum cable lengths when using barriers and isolators are the total capacitance and inductance. Barriers and isolators have a fixed amount of capacitance and inductance that can be connected to their outputs. The cable between the field device and barrier/isolator will have a value for capacitance and inductance per metre or kilometre that will be available from the manufacturer or supplier.

To calculate the maximum cable lengths, calculate the total capacitance and inductance for the length of cable, add any capacitance or inductance due to the field device (in the case of Series 3000 MkIII capacitance and inductance = 0). The resulting totals should not be greater than the value shown for the barrier or isolator.

## Suggested barriers and isolators Series 3000 MkIII

Listed below are some suggested barriers and isolators for use with Series 3000 MkIII.

- MTL7728+ (single channel zener barrier)
- MTL7787+ (2-channel zener barrier)
- MTL5042 (Galvanic Isolator)
- Pepperl+Fuchs KFD2-STC4-EX1 (Galvanic Isolator)

*Note: It is up to the user to ensure that the barrier or isolator used is suitable for their application.*

## Electrical Connections

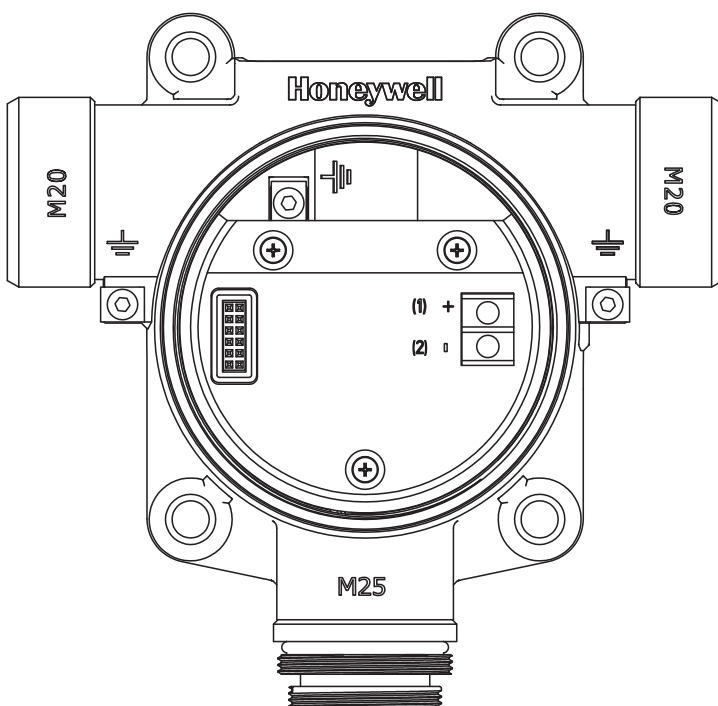

Terminal Number	Detector Terminal	Controller Connection
1	+	+VE
2	-	Signal

# Technical Summary



## Series 3000 MkII and MkIII Detector

**Use** Rugged and reliable gas detector for the protection of personnel from toxic and Oxygen gas hazards. MkII version suitable for use in Zone 1, 2, 21 or 22 hazardous areas and North American Class I and II Division 1 or 2 areas. MkIII version suitable for use in Zone 0, 1, 2, 20, 21 or 22 applications.

### Detectable Gases

Gas	Formula	Selectable Full Scale Range	Default Range	Operating Temperature**	
				Min	Max
Oxygen	O <sub>2</sub>	25.0% / Vol only	25.0%Vol	-30°C / -22°F	55°C / 131°F
Hydrogen Sulphide	H <sub>2</sub> S	10.0 to 50.0ppm	15.0ppm	-40°C / -40°F	55°C / 131°F
Hydrogen Sulphide	H <sub>2</sub> S	50 to 500ppm	100ppm	-40°C / -40°F	55°C / 131°F
Carbon Monoxide	CO	100 to 500ppm	300ppm	-40°C / -40°F	55°C / 131°F
Sulphur Dioxide	SO <sub>2</sub>	5.0 to 20.0ppm	15.0ppm	-40°C / -40°F	55°C / 131°F
Ammonia*	NH <sub>3</sub>	50 to 200ppm	200ppm	-20°C / -4°F	40°C / 104°F <sup>1</sup>
Ammonia*	NH <sub>3</sub>	200 to 1,000ppm	1,000ppm	-20°C / -4°F	40°C / 104°F
Chlorine	Cl <sub>2</sub>	5.0 to 20ppm	5.0ppm	-10°C / 14°F	55°C / 131°F
Chlorine Dioxide	ClO <sub>2</sub>	1.00ppm only	1.00ppm	-20°C / -4°F	55°C / 131°F
Nitric Oxide	NO	100ppm only	100ppm	-20°C / -4°F	55°C / 131°F
Nitrogen Dioxide	NO <sub>2</sub>	5.0 to 50.0ppm	10ppm	-20°C / -4°F	55°C / 131°F
Hydrogen	H <sub>2</sub>	1,000ppm only	1,000ppm	-20°C / -4°F	55°C / 131°F
Hydrogen	H <sub>2</sub>	9,999ppm only	9,999ppm	-20°C / -4°F	55°C / 131°F
Hydrogen Chloride	HCl	10.0 to 20.0ppm	10ppm	-20°C / -4°F	40°C / 104°F



### Electrical

Connections and Power	MkII	MkIII
	2-wire loop powered 17Vdc (±10%) to 32Vdc (max) 22mA max. over range	2 wire loop powered 10Vdc (±10%) to 30Vdc (max) 22mA max. overrange
		Entity parameters for Barrier Selection: Vmax/Ui = 30Vdc Imax/li = 125mA Pmax/Pi = 1.2W Li = 0mH Ci = 0µF
<b>Recommended Cable</b>	2-wire with screen (90% coverage) or conduit 0.5mm <sup>2</sup> (20AWG) to 2.0mm <sup>2</sup> (14AWG)	
<b>Signal</b>	0-100% FSD 4-20mA Fault = 3mA Calibration due selectable off or 3mA Max. over range 22mA Inhibit (toxic sensors) = Selectable 3mA or 4mA Inhibit (Oxygen sensors) = Selectable 3mA or 17.4mA	

### Construction

<b>Material</b>	Transmitter: Epoxy painted aluminium alloy LM25 or 316 Stainless Steel, Sensor: 316 Stainless Steel with PTFE filter
<b>Maximum Dimensions</b>	164mm x 201mm x 99mm (6.4" x 7.9" x 3.9")
<b>Weight</b>	Aluminium alloy LM25: 1.7kg (3.75lbs.) Stainless Steel 316: 3.7kg (8.16lbs.)
<b>Environmental</b>	
<b>IP Rating</b>	IP66 (EN 60529), NEMA 4X
<b>Certified Temperature</b>	ATEX/IECEX: -20°C to +55°C (-4°F to +131°F) (MkIII -40°C to +55°C (-40°F to +131°F)) UL/c-UL: -40°C to +55°C (-40°F to +131°F)
<b>Operating Humidity</b>	Continuous 20-90% RH (non-condensing) Intermittent 0-99% RH (non-condensing)
<b>Operating Pressure</b>	90-110kPa
<b>Storage Conditions</b>	15°C to 30°C (59°F to 86°F), 30-70% RH (non-condensing)

\*Suitable for applications without NH<sub>3</sub> ambient background concentrations only.

\*\*When operating in Hazardous Area applications the detector must not be operated outside the certified temperature range. See Certification details for UL, c-UL and ATEX/IECEX certified temperature ranges.

<sup>1</sup> +55°C / 131°F intermittent.

# Technical Summary and Ordering Information



Certification		
	MkII	MkIII
	<b>Transmitter:</b> UL/c-UL: Class I, Div. 1 & 2, Groups B, C & D; Class II, Div. 1 Groups E, F & G, Class II, Div. 2, Groups F & G; Class I, Zone 1, Group IIB + H2 Hazardous Locations  ATEX: Ⓜ II 2 (1) GD Ex d [ia IIC Ga] IIB + H2 T4 Gb Ex t [ia IIIC Da] IIIB T135°C Db  IECEx: Ex d [ia IIC Ga] IIB + H2 T4 Gb Ex t [ia IIIC Da] IIIB T135°C Db	<b>Transmitter:</b> UL/cUL Class I, Divisions 1 & 2, Groups A, B, C & D; Class II, Divisions 1 & 2, Groups E, F & G  ATEX: Ⓜ II 1 (1) GD Ex ia IIC T4 Ga Ex ia IIIC T135°C Da  IECEx: Ex ia IIC T4 Ga Ex ia IIIC T135°C Da
	<b>Remote Sensor Accessory:</b> UL/c-UL: Class I, Division 1, Groups A, B, C and D Class II, Divisions 1 and 2, Groups E, F and G Class 1, Zone 0, Group IIC; Class II, Zone 20  ATEX: Ⓜ II 1G D Ex ia IIC T4 Ga Ex ia IIIC T135°C Da  IECEx: Ex ia IIC T4 Ga Ex ia IIIC T135°C Da	<b>Remote Sensor Accessory:</b> UL/c-UL = Class I, Div. 1, Groups A, B, C & D; Class II Division 1 & 2, Groups E, F & G; Class 1, Zone 0, Group IIC; Class II, Zone 20  ATEX: Ⓜ II 1G D Ex ia IIC T4 Ga Ex ia IIIC T135°C Da  IECEx: Ex ia IIC T4 Ga Ex ia IIIC T135°C Da
<b>Approvals</b>	CE compliant in accordance with: ATEX Directive 94/9/EC, EMC Directive 2004/108/EC, EN 50270	

## Ordering Information

A complete assembly consists of two parts, a transmitter and sensor which must be ordered separately.

- Transmitter PN#: Two certified versions are available:
  - ATEX/IECEx approved version (Aluminium version part number S3KAL2, S3KAL3 Stainless Steel version part number S3KAS2, S3KAS3)
  - UL/CSA approved version (Aluminium version part number S3KUL2, S3KUL3, Stainless Steel version part number S3KUS2, S3KUS3)
  - Inmetro approved version (Aluminium version part number S3KNL2, S3KNL3, Stainless Steel version part number S3KNS2, S3KNS3)
- Sensor PN#: All certified ATEX, IECEx, UL, CSA (c-UL) with two digits to specify gas type and range:
  - e.g. S3KXXC1SS (C1 denotes Carbon Monoxide, with a default range of 0-300ppm and user configurable for ranges from 0-100ppm to 0-500ppm (in 100ppm steps))

## Transmitter

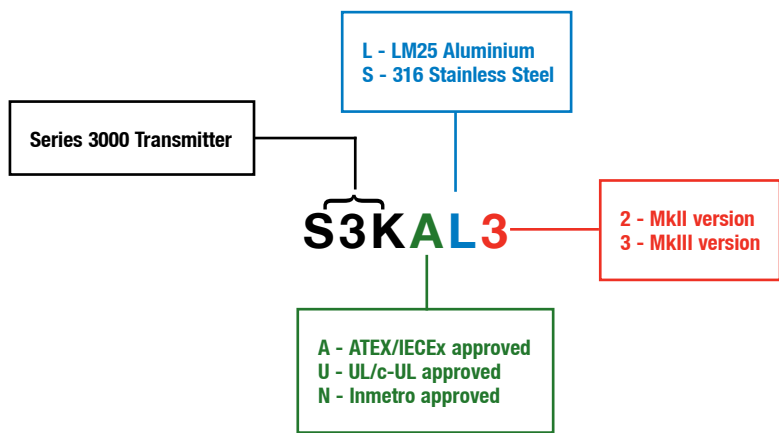

## Sensor Part Numbers and Available Gases

S3KXS01SS	Oxygen (O <sub>2</sub> ) 0-25% Vol
S3KXSC1SS	Carbon Monoxide (CO) 0-300ppm (default) 0-100 to 0-500ppm selectable
S3KXSC2SS	Carbon Monoxide (CO) 0-300ppm (default) 0-100 to 0-999ppm selectable
S3KXSH1SS	Hydrogen Sulphide (H <sub>2</sub> S) 0-15ppm (default) 0-10 to 0-50ppm selectable
S3KXSH2SS	Hydrogen Sulphide (H <sub>2</sub> S) 0-100ppm (default) 0-50 to 0-500ppm selectable
S3KXSL1SS	Chlorine (Cl <sub>2</sub> ) 0-5ppm (default) 0-5 to 0-20ppm selectable

# Ordering Information Continued



## Ordering Information Continued

<b>S3KXSS1SS</b>	Sulphur Dioxide (SO <sub>2</sub> ) 0-15ppm (default) 0-5 to 0-20ppm selectable
<b>S3KXSX1SS</b>	Chlorine Dioxide (ClO <sub>2</sub> ) 0-1ppm only
<b>S3KXSM1SS</b>	Nitrogen Monoxide (NO) 0-100ppm only
<b>S3KXSN1SS</b>	Nitrogen Dioxide (NO <sub>2</sub> ) 0-10 ppm (default) 0-5 to 0-50 ppm selectable
<b>S3KXSG1SS</b>	Hydrogen (H <sub>2</sub> ) 0-1000ppm only
<b>S3KXSG2SS</b>	Hydrogen (H <sub>2</sub> ) 0-10,000 only
<b>S3KXSR1SS</b>	Hydrogen Chloride (HCl) 0-10ppm (default) 0-10 to 0-20ppm selectable
<b>S3KXSA1SS</b>	Ammonia (NH <sub>3</sub> ) 0-200ppm (default) 0-50 to 0-200ppm selectable
<b>S3KXSA2SS</b>	Ammonia (NH <sub>3</sub> ) 0-1000ppm (default) 0-200 to 0-1,000ppm selectable

## Shipping Details

<b>Shipping carton dimensions</b>	315mm (12.4") (L) x 230mm (9.0") (W) x 115mm (4.5") (D)
<b>Approximate weight</b>	Aluminium alloy LM25 : 1.7kg (3.75lbs.) Stainless Steel 316 : 3.7kg (8.16lbs.)

## Optional Accessories

<b>SPXCMTBR</b>	Pipe Mounting Bracket
<b>SPXCSDP</b>	Sunshade/Deluge Protection
<b>S3KCAL</b>	Calibration gas flow housing
<b>S3KCC</b>	Collecting cone (for use when detecting Hydrogen gas only)
<b>S3KDMK</b>	Duct mounting kit (for use when detecting O <sub>2</sub> , CO, H <sub>2</sub> S or H <sub>2</sub> gas)
<b>S3KRMK</b>	ATEX/UL/c-UL approved remote sensor mounting kit (includes enclosure with sensor socket, 15m (50 feet) of digital cable and glands, transmitter cable plug, mounting screws)

<b>Calibration Gases</b>	Contact Honeywell Analytics representative
--------------------------	--



# Our Product Range



## Fixed Gas Monitoring

Honeywell Analytics offers a wide range of fixed gas detection solutions for a diverse array of industries and applications including: Commercial properties, industrial applications, semiconductor manufacturers, energy plants and petrochemical sites.

- » Detection of flammable, Oxygen and toxic gases (including exotics)
- » Innovative use of four core sensing technologies – paper tape, electrochemical cell, catalytic bead and infrared
- » Capability to detect down to Parts Per Billion (ppb) or Percent by Volume (%v/v)
- » Cost effective regulatory compliance solutions

## Portable Gas Monitoring

When it comes to personal protection from gas hazards, Honeywell Analytics has a wide range of reliable solutions ideally suited for use in confined or enclosed spaces.

These include:

- » Detection of flammable, Oxygen and toxic gases
- » Single gas personal monitors – worn by the individual
- » Multi-gas portable gas monitors – used for confined space entry and regulatory compliance
- » Multi-gas transportable monitors – used for temporary protection of area during site construction and maintenance activities

## Technical Services

At Honeywell Analytics, we believe in the value of great service and customer care. Our key commitment is providing complete and total customer satisfaction. Here are just a few of the services we can offer:

- » Full technical support
- » Expert team on hand to answer questions and queries
- » Fully equipped workshops to ensure quick turnaround on repairs
- » Comprehensive service engineer network
- » Training on product use and maintenance
- » Mobile calibration service
- » Customised programmes of preventative/corrective maintenance
- » Extended warranties on products

### Find out more

[www.honeywellanalytics.com](http://www.honeywellanalytics.com)

### Contact Honeywell Analytics:

#### Europe, Middle East, Africa, India

Life Safety Distribution AG  
Javastrasse 2  
8604 Hegnau  
Switzerland  
Tel: +41 (0)44 943 4300  
Fax: +41 (0)44 943 4398  
India Tel: +91 124 4752700  
[gasdetection@honeywell.com](mailto:gasdetection@honeywell.com)

#### Americas

Honeywell Analytics Inc.  
405 Barclay Blvd.  
Lincolnshire, IL 60069  
USA  
Tel: +1 847 955 8200  
Toll free: +1 800 538 0363  
Fax: +1 847 955 8210  
[detectgas@honeywell.com](mailto:detectgas@honeywell.com)

#### Asia Pacific

Honeywell Analytics Asia Pacific  
#508, Kolon Science Valley (I)  
187-10 Guro-Dong, Guro-Gu  
Seoul, 152-050  
Korea  
Tel: +82 (0)2 6909 0300  
Fax: +82 (0)2 2025 0329  
[analytics.ap@honeywell.com](mailto:analytics.ap@honeywell.com)

### Technical Services

EMEAI: [HAexpert@honeywell.com](mailto:HAexpert@honeywell.com)  
US: [ha.us.service@honeywell.com](mailto:ha.us.service@honeywell.com)  
AP: [ha.ap.service@honeywell.com](mailto:ha.ap.service@honeywell.com)

[www.honeywell.com](http://www.honeywell.com)

Locally available from

**ANSAC**

35, Marsiling Industrial Estate Road 3, #02-01 Singapore 739257  
T: (65) 6368 0225 F: (65) 6368 8023  
E: [sales@ansac-tech.com.sg](mailto:sales@ansac-tech.com.sg) | [www.ansac-tech.com.sg](http://www.ansac-tech.com.sg)

### Please Note:

While every effort has been made to ensure accuracy in this publication, no responsibility can be accepted for errors or omissions. Data may change, as well as legislation, and you are strongly advised to obtain copies of the most recently issued regulations, standards, and guidelines. This publication is not intended to form the basis of a contract.

H\_Series 3000 MkII & MkIII\_DS01057\_V7\_EMEAI  
03/13

© 2013 Honeywell Analytics

We Save Lives

